

REVISIONS			
LTR	DESCRIPTION	DATE	APPROVED
A	NEW DRAWING		
B	REVISED PER ECN 11310		
C	REVISED PER ECN 27084	01/01	

NOTES:

1. DIMENSIONS D1 AND E1 INCLUDE MOLD MISMATCH, BUT DO NOT INCLUDE MOLD PROTRUSION; ALLOWABLE PROTRUSION IS 0.254 MM ON D1 AND E1.
2. DETAILS OF PIN 1 IDENTIFIER ARE OPTIONAL BUT MUST BE LOCATED WITHIN THE ZONE INDICATED.
3. ALLOWABLE DAMBAR PROTRUSION IS 0.08 MM TOTAL IN EXCESS OF THE B DIMENSION AT MAXIMUM MATERIAL CONDITION. PROTRUSION NOT TO BE LOCATED ON LOWER RADIUS OR FOOT OF LEAD.

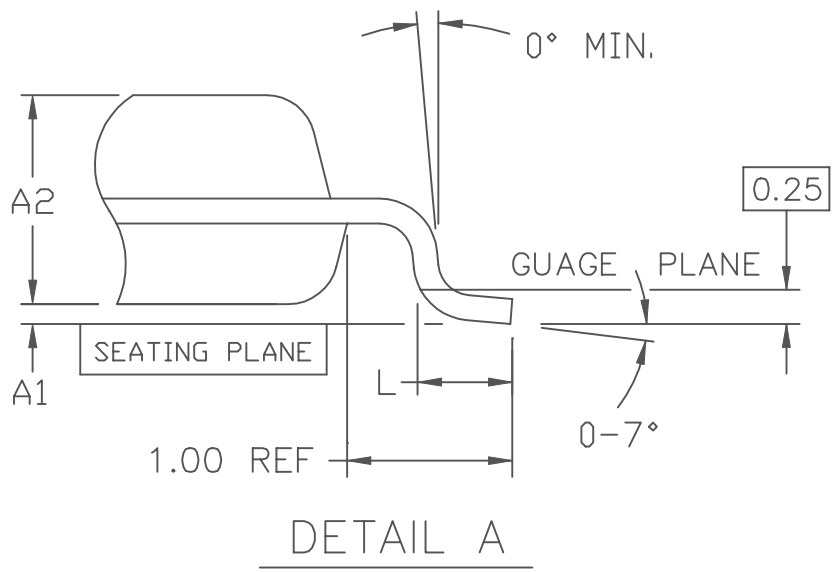
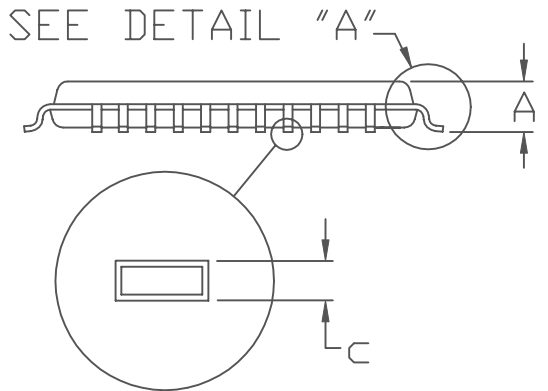

DIM	MIN	NOM	MAX
A	-	-	1.20
A1	0.05	0.10	0.15
A2	0.95	1.00	1.05
b	0.22	0.32	0.38
c	0.09	-	0.20
D	11.80	12.00	12.20
D1	10.00 BSC		
E	11.80	12.00	12.20
E1	10.00 BSC		
e	0.65 BSC		
L	0.45	0.60	0.75

DIMENSIONS ARE IN MILLIMETERS

SIGNATURE	DATE
DOC. CONTROL:	
ENGR. MGR:	
MFG. ENGR:	
CHECKED BY:	
DRAWN BY: J. DAVIS	01/01



TITLE MARKETING OUTLINE, 52 LD. TQFP, 10X10X1.0 BODY, 1.0/0.1 FORM			
SIZE A	FSCM NO	PART NO. 56-G4014-001	REV C