

December 1993

8-Bit Multiplying D/A Converters

Features

- 8, 9 and 10-Bit Linearity
- Low Gain and Linearity Temperature Coefficients
- Full Temperature Range Operation
- Static Discharge Input Protection
- TTL/CMOS Compatible
- +5V to +15V Supply Range
- Fast Settling Time: 150ns Max at +25°C
- Four Quadrant Multiplication
- AD7533 Direct AD7520 Equivalent

Description

The AD7523 and AD7533 monolithic, low cost, high performance, 8-bit and 10-bit accurate, multiplying digital-to-analog converter (DAC), in a 16 pin DIP.

Harris' thin film resistors on CMOS circuitry provide 10-bit resolution (8, 9 and 10-bit accuracy), with TTL/CMOS compatible operation.

The AD7523 and AD7533s accurate four quadrant multiplication, full military temperature range operation, full input protection from damage due to static discharge by clamps to V+ and GND, and very low power dissipation make it a very versatile converter.

Low noise audio gain controls, motor speed controls, digitally controlled gain and digital attenuators are a few of the wide range of applications of the AD7523 and AD7533.

Ordering Information

PART NUMBER	NONLINEARITY	TEMPERATURE RANGE	PACKAGE
AD7523JN, AD7533JN	0.2% (8-Bit)	0°C to +70°C	16 Lead Plastic DIP
AD7523KN, AD7533KN	0.1% (9-Bit)	0°C to +70°C	16 Lead Plastic DIP
AD7523LN, AD7533LN	0.05% (10-Bit)	0°C to +70°C	16 Lead Plastic DIP

Pinout

AD7523, AD7533 (CDIP, PDIP)
TOP VIEW

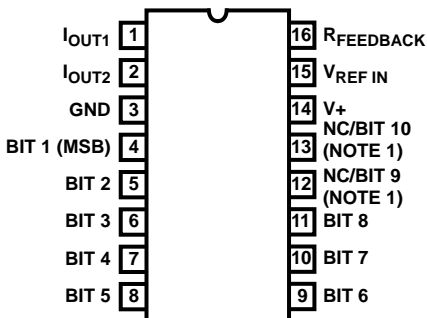

NOTE:

1. NC for AD7523 only.

Functional Block Diagram

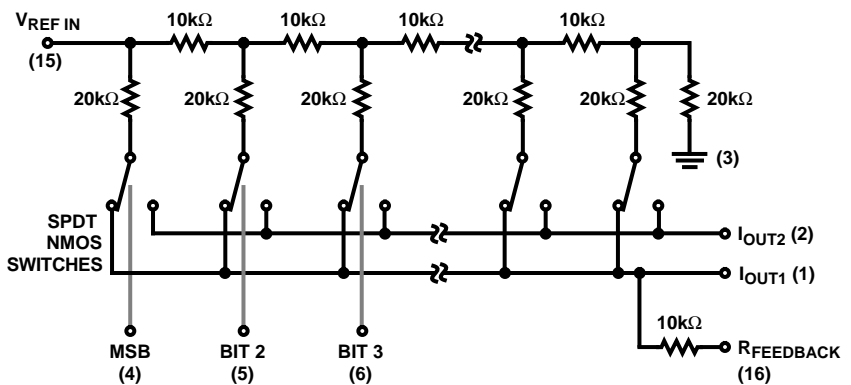

Switches shown for digital inputs "High"

Specifications AD7523, AD7533

Absolute Maximum Ratings

Supply Voltage (V+ to GND).....	+17V
V _{REF}	±25V
Digital Input Voltage Range	V+ to GND
Output Voltage Compliance	-100mV to V+
Storage Temperature	-65°C to +150°C
Lead Temperature (Soldering 10s).....	+300°C

Thermal Information

Thermal Resistance	θ_{JA}
Plastic DIP Package	100°C/W
Operating Temperature	
JN, KN, LN Versions	0°C to +70°C

CAUTION: Stresses above those listed in "Absolute Maximum Ratings" may cause permanent damage to the device. This is a stress only rating and operation of the device at these or any other conditions above those indicated in the operational sections of this specification is not implied.

Electrical Specifications V+ = +15V, V_{REF} = +10V, V_{OUT1} = V_{OUT2} = 0V, Unless Otherwise Specified

PARAMETER		TEST CONDITIONS	AD7523				AD7533				UNITS
			T _A +25°C		T _A MIN-MAX		T _A +25°C		T _A MIN-MAX		
			MIN	MAX	MIN	MAX	MIN	MAX	MIN	MAX	
SYSTEM PERFORMANCE											
Resolution			8	-	8	-	10	-	10	-	Bits
Nonlinearity	J	-10V ≤ V _{REF} ≤ +10V V _{OUT1} = V _{OUT2} = 0V (Note 1, 2, 5)	-	±0.2	-	±0.2	-	±0.2	-	±0.2	% of FSR
	K, T		-	±0.1	-	±0.1	-	±0.1	-	±0.1	% of FSR
	L		-	±0.05	-	±0.05	-	±0.05	-	±0.05	% of FSR
Monotonicity			Guaranteed				Guaranteed				
Gain Error		All Digital Inputs High (Note 2)	-	±1.5	-	±1.8	-	±1.4	-	±1.8	% of FSR
Nonlinearity Tempco		-10V ≤ V _{REF} ≤ +10V (Notes 2, 3)	-	±2	-	±2	-	±2	-	±2	ppm of FSR/°C
Gain Error Tempco			-	±10	-	±10	-	±10	-	±10	ppm of FSR/°C
Output Leakage Current (Either Output)		V _{OUT1} = V _{OUT2} = 0	-	±50	-	±200	-	±50	-	±200	nA
DYNAMIC CHARACTERISTICS											
Power Supply Rejection		V+ = 14.0V to 15.0V (Note 2)	-	±0.02	-	±0.03	-	±0.005	-	±0.008	% of FSR/% of ΔV+
Output Current Settling Time		To 0.2% of FSR, R _L = 100Ω (Note 3)	-	150	-	200	-	600	-	800	ns
Feedthrough Error		V _{REF} = 20Vpp, 200kHz Sine Wave, All Digital Inputs Low (Note 3)	-	±1/2	-	±1	-	±0.05	-	±0.1	LSB
REFERENCE INPUTS											
Input Resistance (Pin 15)		All Digital Inputs High I _{OUT1} at Ground (Note 3)	5	-	5	-	5	-	5	-	kΩ
			-	20	-	20	-	20	-	20	kΩ
Temperature Coefficient			-	-500	-	-500	-	-300	-	-300	ppm/°C

AD7523, AD7533

Electrical Specifications $V_+ = +15V$, $V_{REF} = +10V$, $V_{OUT1} = V_{OUT2} = 0V$, Unless Otherwise Specified (Continued)

PARAMETER	TEST CONDITIONS	AD7523				AD7533				UNITS	
		$T_A +25^\circ C$		T_A MIN-MAX		$T_A +25^\circ C$		T_A MIN-MAX			
		MIN	MAX	MIN	MAX	MIN	MAX	MIN	MAX		
ANALOG OUTPUT											
Output Capacitance	C_{OUT1}	All Digital Inputs High (Note 3)	-	100	-	100	-	100	-	100	pF
	C_{OUT2}		-	30	-	30	-	35	-	35	pF
	C_{OUT1}	All Digital Inputs Low (Note 3)	-	30	-	30	-	35	-	35	pF
	C_{OUT2}		-	100	-	100	-	100	-	100	pF
DIGITAL INPUTS											
Low State Threshold, V_{IL}			-	0.8	-	0.8	-	0.8	-	0.8	V
High State Threshold, V_{IH}			2,4	-	2,4	-	2.4	-	2.4	-	V
Input Current (Low or High), I_{IL} , I_{IH}		$V_{IN} = 0V$ or $+15V$	-	± 1	-	± 1	-	± 1	-	± 1	μA
Input Coding		See Tables 1 & 3	Binary/Offset Binary				Binary/Offset Binary				
Input Capacitance		(Note 3)	-	4	-	4	-	4	-	4	pF
POWER SUPPLY CHARACTERISTICS											
Power Supply Voltage Range		(Note 5)	+5 to +16				+5 to +16				V
I_+		All Digital Inputs High or Low (Excluding Ladder Network)	-	2	-	2.5	-	2	-	2.5	mA

NOTES:

1. Full scale range (FSR) is 10V for unipolar and $\pm 10V$ for bipolar modes.
2. Using internal feedback resistor, $R_{FEEDBACK}$.
3. Guaranteed by design or characterization and not production tested.
4. Accuracy not guaranteed unless outputs at ground potential.
5. Accuracy is tested and guaranteed at $V_+ = +15V$, only.

Definition of Terms

Nonlinearity: Error contributed by deviation of the DAC transfer function from a "best straight line" through the actual plot of transfer function. Normally expressed as a percentage of full scale range or in (sub)multiples of 1 LSB.

Resolution: It is addressing the smallest distinct analog output change that a D/A converter can produce. It is commonly expressed as the number of converter bits. A converter with resolution of n bits can resolve output changes of 2^{-N} of the full-scale range, e.g. $2^{-N} V_{REF}$ for a unipolar conversion. Resolution by no means implies linearity.

Settling Time: Time required for the output of a DAC to settle to within specified error band around its final value (e.g. 1/2 LSB) for a given digital input change, i.e. all digital inputs LOW to HIGH and HIGH to LOW.

Gain Error: The difference between actual and ideal analog output values at full-scale range, i.e. all digital inputs at HIGH state. It is expressed as a percentage of full-scale range or in (sub)multiples of 1 LSB.

Feedthrough Error: Error caused by capacitive coupling from V_{REF} to I_{OUT1} with all digital inputs LOW.

Output Capacitance: Capacitance from I_{OUT1} , and I_{OUT2} terminals to ground.

Output Leakage Current: Current which appears on I_{OUT1} , terminal when all digital inputs are LOW or on I_{OUT2} terminal when all digital inputs are HIGH.

For further information on the use of this device, see the following Application Notes:

- A002** "Principles of Data Acquisition and Conversion"
- A018** "Do's and Don'ts of Applying A/D Converters", by Peter Bradshaw and Skip Osgood
- A042** "Interpretation of Data Conversion Accuracy Specifications"

Detailed Description

The AD7523 and AD7533 are monolithic multiplying D/A converters. A highly stable thin film R-2R resistor ladder network and NMOS SPDT switches form the basis of the converter circuit, CMOS level shifters permit low power TTL/CMOS compatible operation. An external voltage or current reference and an operational amplifier are all that is required for most voltage output applications.

A simplified equivalent circuit of the DAC is shown in the Functional Diagram. The NMOS SPDT switches steer the ladder leg currents between I_{OUT1} and I_{OUT2} buses which must be held at ground potential. This configuration maintains a constant current in each ladder leg independent of the input code.

Converter errors are further reduced by using separate metal interconnections between the major bits and the outputs. Use of high threshold switches reduce offset (leakage) errors to a negligible level.

The level shifter circuits are comprised of three inverters with positive feedback from the output of the second to the first, see Figure 1. This configuration results in TTL/CMOS compatible operation over the full military temperature range. With the ladder SPDT switches driven by the level shifter, each switch is binarily weighted for an ON resistance proportional to the respective ladder leg current. This assures a constant voltage drop across each switch, creating equipotential terminations for the 2R ladder resistors and high accurate leg currents.

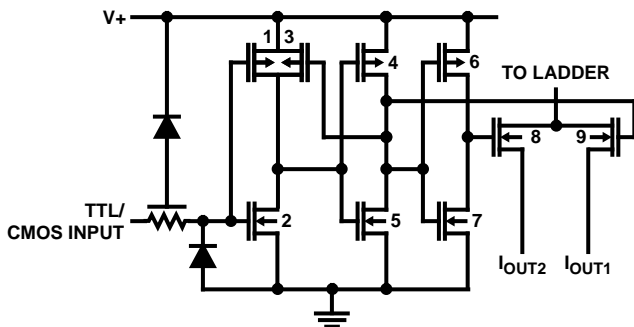
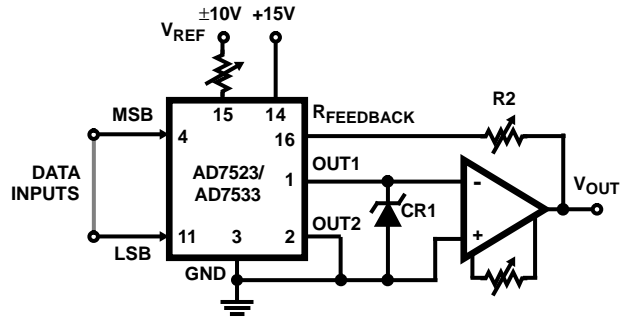

FIGURE 1. CMOS SWITCH

Typical Applications

Unipolar Binary Operation - AD7523 (8 Bit DAC)

The circuit configuration for operating the AD7523 in unipolar mode is shown in Figure 2. With positive and negative V_{REF} values the circuit is capable of 2-Quadrant multiplication. The "Digital Input Code/Analog Output Value" table for unipolar mode is given in Table 1.



NOTES:

1. R1 and R2 used only if gain adjustment is required.
2. CF1 protects AD7523 and AD7533 against negative transients.

FIGURE 2. UNIPOLAR BINARY OPERATION

TABLE 1. UNIPOLAR BINARY CODE - AD7523

DIGITAL INPUT MSB LSB	ANALOG OUTPUT
11111111	$-V_{REF} \left(\frac{255}{256} \right)$
10000001	$-V_{REF} \left(\frac{129}{256} \right)$
10000000	$-V_{REF} \left(\frac{128}{256} \right) = -\frac{V_{REF}}{2}$
01111111	$-V_{REF} \left(\frac{127}{256} \right)$
00000001	$-V_{REF} \left(\frac{1}{256} \right)$
00000000	$-V_{REF} \left(\frac{0}{256} \right) = 0$

NOTES:

1. $1 \text{ LSB} = (2^{-8}) (V_{REF}) = \left(\frac{1}{256} \right) (V_{REF})$

Zero Offset Adjustment

1. Connect all digital inputs to GND.
2. Adjust the offset zero adjust trimpot of the output operational amplifier for $0V \pm 1mV$ (max) at V_{OUT} .

Gain Adjustment

1. Connect all digital inputs to $V+$.
2. Monitor V_{OUT} for a $-V_{REF} (1 - 1/2^8)$ reading.
3. To increase V_{OUT} , connect a series resistor, R2, (0Ω to 250Ω) in the I_{OUT1} amplifier feedback loop.
4. To decrease V_{OUT} , connect a series resistor, R1, (0Ω to 250Ω) between the reference voltage and the V_{REF} terminal.

Unipolar Binary Operation - AD7533 (10 Bit DAC)

The circuit configuration for operating the AD7533 in unipolar mode is shown in Figure 2. With positive and negative V_{REF} values the circuit is capable of 2-Quadrant multiplication. The "Digital Input Code/Analog Output Value" table for unipolar mode is given in Table 2.

TABLE 2. UNIPOLAR BINARY CODE - AD7533

DIGITAL INPUT MSB LSB	(NOTE 1) NOMINAL ANALOG OUTPUT
1111111111	$-V_{REF} \left(\frac{1023}{1024} \right)$
1000000001	$-V_{REF} \left(\frac{513}{1024} \right)$
1000000000	$-V_{REF} \left(\frac{512}{1024} \right) = -\frac{V_{REF}}{2}$
0111111111	$-V_{REF} \left(\frac{511}{1024} \right)$
0000000001	$-V_{REF} \left(\frac{1}{1024} \right)$
0000000000	$-V_{REF} \left(\frac{0}{1024} \right) = 0$

NOTES:

- V_{OUT} as shown in the Functional Diagram.
- Nominal Full Scale for the circuit of Figure 2 is given by

$$FS = -V_{REF} \left(\frac{1023}{1024} \right)$$
- Nominal LSB magnitude for the circuit of Figure 2 is given by

$$LSB = V_{REF} \left(\frac{1}{1024} \right)$$

Zero Offset Adjustment

- Connect all digital inputs to GND.
- Adjust the offset zero adjust trimpot of the output operational amplifier for $0V \pm 1mV$ (max) at V_{OUT} .

Gain Adjustment

- Connect all digital inputs to $V+$.
- Monitor V_{OUT} for a $-V_{REF} (1 - 1/2^{10})$ reading.
- To increase V_{OUT} , connect a series resistor, R2, (0Ω to 250Ω) in the I_{OUT1} amplifier feedback loop.
- To decrease V_{OUT} , connect a series resistor, R1, (0Ω to 250Ω) between the reference voltage and the V_{REF} terminal.

Bipolar (Offset Binary) Operation - AD7523

The circuit configuration for operating the AD7523 in the bipolar mode is given in Figure 3. Using offset binary digital input codes and positive and negative reference voltage values, Four-Quadrant multiplication can be realized. The "Digital Input Code/Analog Output Value" table for bipolar mode is given in Table 3.)

TABLE 3. BIPOLAR (OFFSET BINARY) CODE - AD7523

DIGITAL INPUT MSB LSB	ANALOG OUTPUT
11111111	$-V_{REF} \left(\frac{127}{128} \right)$
10000001	$-V_{REF} \left(\frac{1}{128} \right)$
10000000	0
01111111	$+V_{REF} \left(\frac{1}{128} \right)$
00000001	$+V_{REF} \left(\frac{127}{128} \right)$
00000000	$+V_{REF} \left(\frac{128}{128} \right)$

NOTES:

- $1 \text{ LSB} = (2^{-7}) (V_{REF}) = \left(\frac{1}{128} \right) (V_{REF})$

A "Logic 1" input at any digital input forces the corresponding ladder switch to steer the bit current to I_{OUT1} bus. A "Logic 0" input forces the bit current to I_{OUT2} bus. For any code the

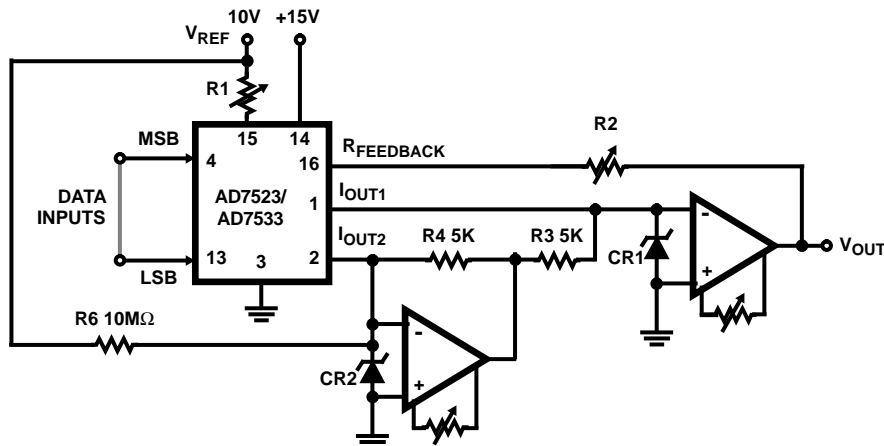

FIGURE 3. BIPOLAR OPERATION (4-QUADRANT MULTIPLICATION)

AD7523, AD7533

I_{OUT1} and I_{OUT2} bus currents are complements of one another. The current amplifier at I_{OUT2} changes the polarity of I_{OUT2} current and the transconductance amplifier at I_{OUT} output sums the two currents. This configuration doubles the output range. The difference current resulting at zero offset binary code, (MSB = "Logic 1", all other bits = "Logic 0"), is corrected by using an external resistor, (10M Ω), from V_{REF} to I_{OUT2} (Figure 3).

Offset Adjustment

1. Adjust V_{REF} to approximately +10V.
2. Connect all digital inputs to "Logic 1".
3. Adjust I_{OUT2} amplifier offset adjust trimpot for 0V \pm 1mV at I_{OUT2} amplifier output.
4. Connect MSB (Bit 1) to "Logic 1" and all other bits to "Logic 0".
5. Adjust I_{OUT1} amplifier offset adjust trimpot for 0V \pm 1mV at V_{OUT} .

Gain Adjustment

1. Connect all digital inputs to $V+$.
2. Monitor V_{OUT} for a $-V_{REF}$ (1 - 1/2⁸) volts reading.
3. To increase V_{OUT} , connect a series resistor, R2, of up to 250 Ω between V_{OUT} and $R_{FEEDBACK}$.
4. To decrease V_{OUT} , connect a series resistor, R1, of up to 250 Ω between the reference voltage and the V_{REF} terminal.

Bipolar (Offset Binary) Operation - AD7533

The circuit configuration for operating the AD7533 in the bipolar mode is given in Figure 3. Using offset binary digital input codes and positive and negative reference voltage values, 4-Quadrant multiplication can be realized. The "Digital Input Code/Analog Output Value" table for bipolar mode is given in Table 4.

A "Logic 1" input at any digital input forces the corresponding ladder switch to steer the bit current to I_{OUT1} bus. A "Logic 0" input forces the bit current to I_{OUT2} bus. For any code the I_{OUT1} and I_{OUT2} bus currents are complements of one another. The current amplifier at I_{OUT2} changes the polarity of I_{OUT2} current and the transconductance amplifier at I_{OUT1} output sums the two currents. This configuration doubles the output range. The difference current resulting at zero offset binary code, (MSB = "Logic 1", all other bits = "Logic 0"), is corrected by using an external resistor, (10M Ω), from V_{REF} to I_{OUT2} .

TABLE 4. UNIPOLAR BINARY CODE - AD7533

DIGITAL INPUT MSB LSB	(NOTE 1) NOMINAL ANALOG OUTPUT
1111111111	$-V_{REF} \left(\frac{511}{512} \right)$
1000000001	$-V_{REF} \left(\frac{1}{512} \right)$
1000000000	0
0111111111	$+V_{REF} \left(\frac{1}{512} \right)$
0000000001	$+V_{REF} \left(\frac{511}{512} \right)$
0000000000	$+V_{REF} \left(\frac{512}{512} \right)$

NOTES:

1. V_{OUT} as shown in the Functional Diagram.
2. Nominal Full Scale for the circuit of Figure 6 is given by

$$FSR = V_{REF} \left(\frac{1023}{512} \right)$$
3. Nominal LSB magnitude for the circuit of Figure 3 is given by

$$LSB = V_{REF} \left(\frac{1}{512} \right)$$

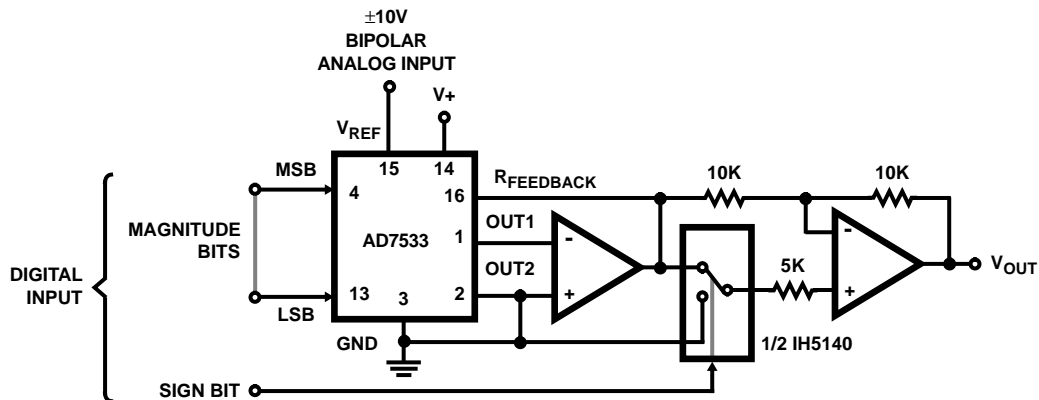

FIGURE 4. 10-BIT AND SIGN MULTIPLYING DAC

AD7523, AD7533

Offset Adjustment

1. Adjust V_{REF} to approximately +10V.
2. Connect all digital inputs to "Logic 1".
3. Adjust I_{OUT2} amplifier offset adjust trimpot for $0V \pm 1mV$ at I_{OUT2} amplifier output.
4. Connect MSB (Bit 1) to "Logic 1" and all other bits to "Logic 0".
5. Adjust I_{OUT1} amplifier offset adjust trimpot for $0V \pm 1mV$ at V_{OUT} .

Gain Adjustment

1. Connect all digital inputs to V_+ .
2. Monitor V_{OUT} for a $-V_{REF} (1 - 2^{-9})$ volts reading.
3. To increase V_{OUT} , connect a series resistor of up to 250Ω between V_{OUT} and $R_{FEEDBACK}$.
4. To decrease V_{OUT} , connect a series resistor of up to 250Ω between the reference voltage and the V_{REF} terminal.

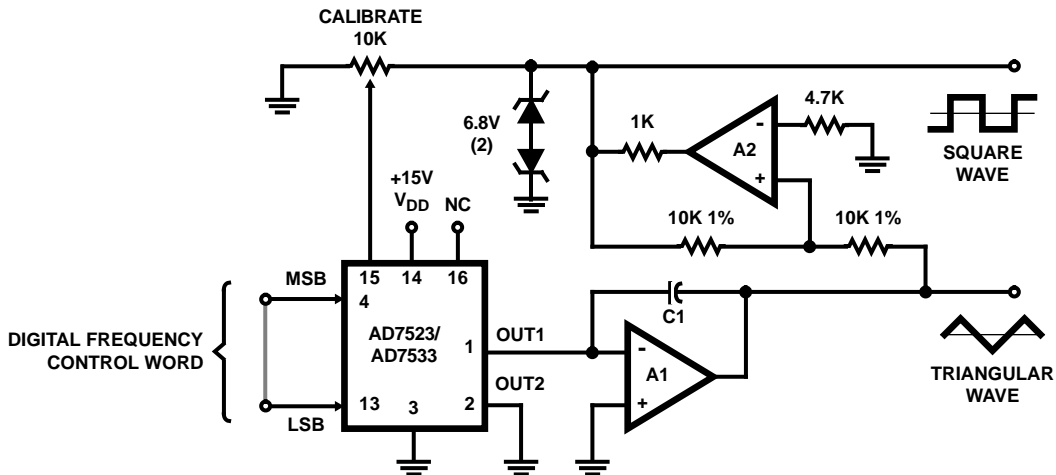
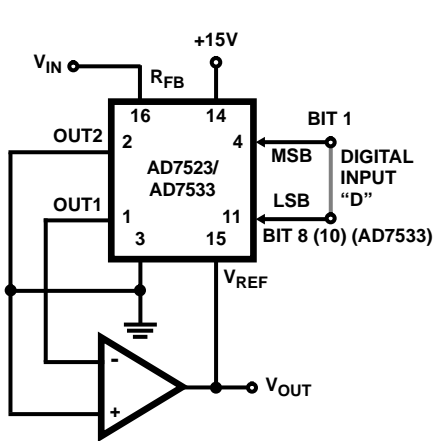

FIGURE 5. PROGRAMMABLE FUNCTION GENERATOR



$V_{OUT} = -V_{IN}/D$
Where:

$$D = \frac{\text{Bit}1}{2^1} + \frac{\text{Bit}2}{2^2} + \dots + \frac{\text{Bit}8}{2^8}$$

$$(0 \leq D \leq \frac{255}{256})$$

FIGURE 6. DIVIDER (DIGITALLY CONTROLLED GAIN)

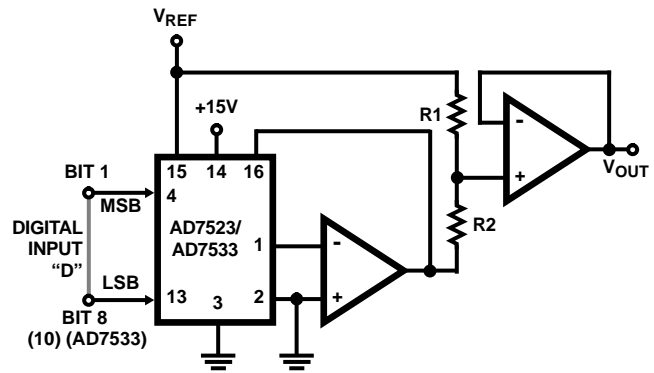

$$V_{OUT} = V_{REF} \left[\left(\frac{R_2}{R_1 + R_2} \right) - \left(\frac{R_1 D}{R_1 + R_2} \right) \right]$$

$$\text{Where } D = \frac{\text{Bit}1}{2^1} + \frac{\text{Bit}2}{2^2} + \dots + \frac{\text{Bit}8}{2^8}$$

$$(0 \leq D \leq \frac{255}{256})$$

FIGURE 7. MODIFIED SCALE FACTOR AND OFFSET

AD7523, AD7533

Die Characteristics

DIE DIMENSIONS:

101 x 103mils (2565 x 2616micrms)

METALLIZATION:

Type: Pure Aluminum
 Thickness: $10 \pm 1\text{k}\text{\AA}$

GLASSIVATION:

Type: PSG/Nitride
 PSG: $7 \pm 1.4\text{k}\text{\AA}$
 Nitride: $8 \pm 1.2\text{k}\text{\AA}$

PROCESS: CMOS Metal Gate

Metallization Mask Layout

